

Fig. 36
BS 6.8 Screw for fixing in thin metal sheets

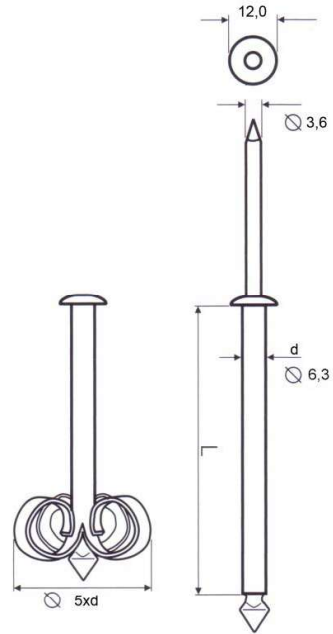

Fig. 37
GPR 6.3 Peel Rivet

Table 4: Profiled steel sheets substrate ³⁾

Fastener	Substrate	Washer ⁵⁾	R _k : Characteristic values of axial load resistance (kN)	Durability Resistance to unwinding EAD 030351-00-0402 cl. 5.3.7 D.2.3, D.3.1, D.3.2 and cl. 5.3.4 D.2.2
GUARDIAN PS 4.8	Steel sheet 0.70mm	SP 50	1.31	Approved
GUARDIAN PS 4.8	Steel sheet 0.75mm	SP 50	1.52	Approved
GUARDIAN PS 4.8	Steel sheet 1.00mm	SP 50	1.94	Approved
GUARDIAN BS 4.8	Steel sheet 0.70mm	SP 50	1.17	Approved
GUARDIAN BS 4.8	Steel sheet 0.70mm ⁴⁾	SP 40	1.35	Approved
GUARDIAN BS 4.8	Steel sheet 0.75mm	SP 50	1.45	Approved
GUARDIAN BS 4.8	Steel sheet 0.80mm	SP 50	1.54	Approved
GUARDIAN BSHD 4.8	Steel sheet 1.00mm	SP 50	1.65	Approved
GUARDIAN BSHD 4.8	Steel sheet 1.25mm	SP 50	2.10	Approved
GUARDIAN BSRF 4.8	Steel sheet 0.75mm ⁴⁾	SP 50	1.02	Approved
GUARDIAN BS 5.5	Steel sheet 0.72mm ⁴⁾	SP 50	1.74	Approved
GUARDIAN BS 6.1	Steel sheet 0.60mm	Sleeve R 45	1.56	Approved
GUARDIAN BS 6.1	Steel sheet 0.70mm	SP 50	1.78	Approved
GUARDIAN BS 6.1	Steel sheet 0.75mm	SP 50	1.98	Approved
GUARDIAN BS 6.1	Steel sheet 1.00mm	SP 50	2.77	Approved
GUARDIAN BS 6.8	Steel sheet 0.50mm	SP 50	1.06	Approved
GUARDIAN BS 6.8	Steel sheet 0.60mm	SP 50	1.31	Approved
GUARDIAN BS 6.8	Steel sheet 0.70mm	SP 50	1.78	Approved
GUARDIAN DBT 4.8	Steel sheet 0.70mm	SPA 8240	1.17	Approved
GUARDIAN DBT 4.8	Steel sheet 0.75mm	SPA 8240	1.41	Approved
GUARDIAN DBT 4.8	Steel sheet 0.80mm	SPA 8240	1.52	Approved
GUARDIAN DBT(A)S 4.8	Steel sheet 0.75mm ⁴⁾	SPA 8240	1.16	Approved
GUARDIAN GPR 6.3	Steel sheet 0.50mm	SP 50	1.19	Approved

³⁾ Steel sheets, galvanized, min S280 according to EN 10147

⁴⁾ Steel sheets, galvanized, yieldstrength 320 MPa

⁵⁾ Obtained value from the axial load test in steel sheets substrates, table 4, and the pullover test, table 6, of washers is compared and the lowest of the two gives the characteristic value for the fastener / sleeve, washer combination of the application.

Table 6: Pullover test of washer

Washer	Fastener ¹³⁾ Guardian														R _k : Characteristic values of axial load resistance	Durability according to EAD 030351-00- 0402		
	ACS 6.1	BS 4.8	BS 5.5	BS 6.1	BS 6.8	BSHD 4.8	BSRF 4.8	CS 6.1 / CS S 6.1	DB(A) 4.8	DBT(A) 4.8	DBT(A)-S 4.8	HD 6.1	LBS 6.0 / LBS S 6.0	LBS-8.0			PS 4.8	TS 5.2
SP-40 – D/F/DD/FD	-	X	X	X	X	X	X	X	-	-	-	X	X	-	X	X	3.88	Approved
SP-40-LBS	-													X			4.29	Approved
SP-50-D. F. S	-	X	X	X	X	X	X	X	-	-	-	X	X	-	X	X	4.83	Approved
SPB-50-S	-	X	X	X	X	X	X	X	-	-	-	X	X	-	X	X	4.83	Approved
SP-70-D. F. S	-	X	X	X	X	X	X	X	-	-	-	X	X	-	X	X	2.88	Approved
SP 8240-D/F/S	-	X	X	X	X	X	X	X	-	-	-	X	X	-	X	X	5.30	Approved
SPA 8240-D/F	-	-	-	-	-	-	-	-	X	X	X	-	-	-	-	-	5.00	Approved
STBS	-	X	X	X	X	X	X	X	-	-	-	X	X	-	X	X	3.68	Approved
Sleeve R23 – STBT	-	X	X	X	X	X	X	X	-	-	-	X	X	-	X	X	1.78	Approved
Sleeve R23 – STBS7T15	-	X	X	X	X	X	X	X	-	-	-	X	X	-	X	X	1.78	Approved
Guardian screw-STBS7T15	-	X	X	X	X	X	X	X	-	-	-	X	X	-	X	X	3.68	Approved
STBST	-	X	X	X	X	X	X	X	-	-	-	X	X	-	X	X	3.68	Approved
Sarnabar + R23	X	X	X	X	X	X	X	X	-	-	-	X	X	-	X	X	1.78	Approved
Sarnabar + Guardian screw	-	X	X	X	X	X	X	X	X	X	X	X	X	-	X	X	5.00	Approved
GWSP (*)-80-F2E	-	-	X	X	X	-	-	X	-	-	-	-	X	-	-	X	2.48	Approved
Sleeve GWT + GWSP (*)-80-F4E	-	X	X	X	X	X	X	X	-	-	-	X	X	-	X	X	3.17	Approved
Sleeve R 45	-	X	X	X	X	X	X	X	-	-	-	X	X	-	X	X	1.58	Approved
Sleeve RPA 45	-	X	X	X	X	X	X	X	-	-	-	X	X	-	X	X	3.00	Approved
Sleeve R 48	-	X	X	X	X	X	X	X	-	-	-	X	X	-	X	X	1.58	Approved
Sleeve RPA 48	-	X	X	X	X	X	X	X	-	-	-	X	X	-	X	X	3.00	Approved
Sleeve RB 48	-	X	X	X	X	X	X	X	-	-	-	X	X	-	X	X	1.58	Approved
Sleeve RBPA 48	-	X	X	X	X	X	X	X	-	-	-	X	X	-	X	X	3.00	Approved
Sleeve RBS 50	-	X	X	X	X	X	X	X	-	-	-	X	X	-	X	X	1.58	Approved
Sleeve R 75	-	X	X	X	X	X	X	X	-	-	-	X	X	-	X	X	1.58	Approved
Sleeve TBPP 8040	-	X	X	X	X	X	X	X	-	-	-	X	X	-	X	X	1.58	Approved
Sleeve TBPA 8040	-	X	X	X	X	X	X	X	-	-	-	X	X	-	X	X	2.52	Approved
PP 45	-	X	X	X	-	X	X	X	-	-	-	-	X	-	X	X	2.50	Approved
Sleeve HR 45	X	-	-	-	-	-	-	-	-	-	-	-	-	-	-	-	1.58	Approved
Sleeve HR 48	X	-	-	-	-	-	-	-	-	-	-	-	-	-	-	-	1.58	Approved
Sleeve HR 75	X	-	-	-	-	-	-	-	-	-	-	-	-	-	-	-	1.58	Approved
Sleeve R45-LN	-	-	-	-	-	-	-	-	-	-	-	-	-	X	-	-	1.58	Approved
Sleeve R48-LN	-	-	-	-	-	-	-	-	-	-	-	-	-	X	-	-	1.58	Approved
Sleeve R75-LN	-	-	-	-	-	-	-	-	-	-	-	-	-	X	-	-	1.58	Approved

¹³⁾Obtained values from the axial load test in different substrates (table 2 - 5) and the pullover test (table 6) of washers/sleeves are compared and the lowest of the two gives the characteristic value for the fastener / sleeve, washer combination of the application.